

**DETAIL OF MOUNTING BLOCK**

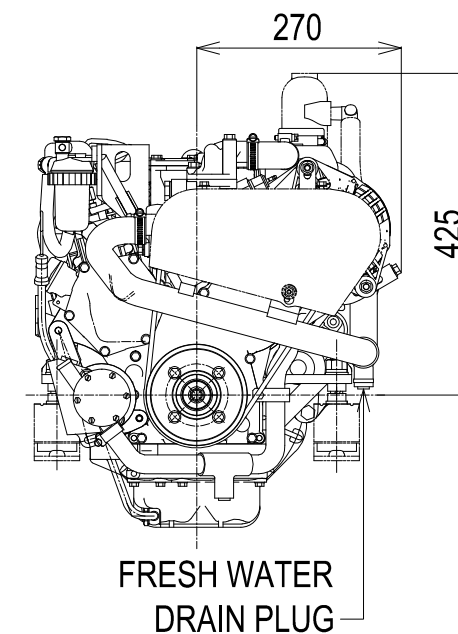

**DETAIL OF COUPLING**

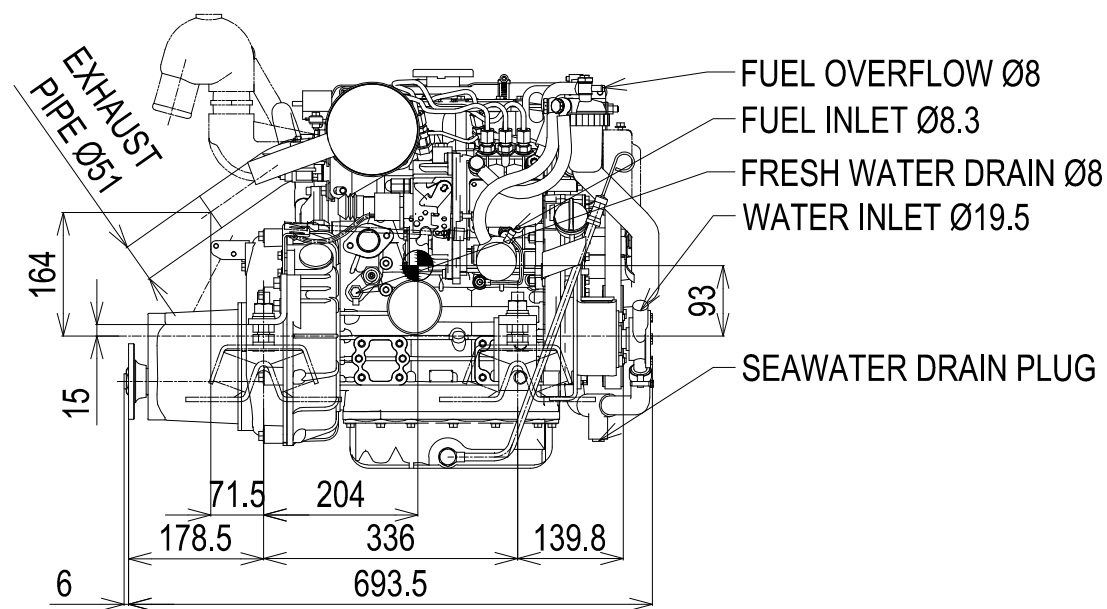
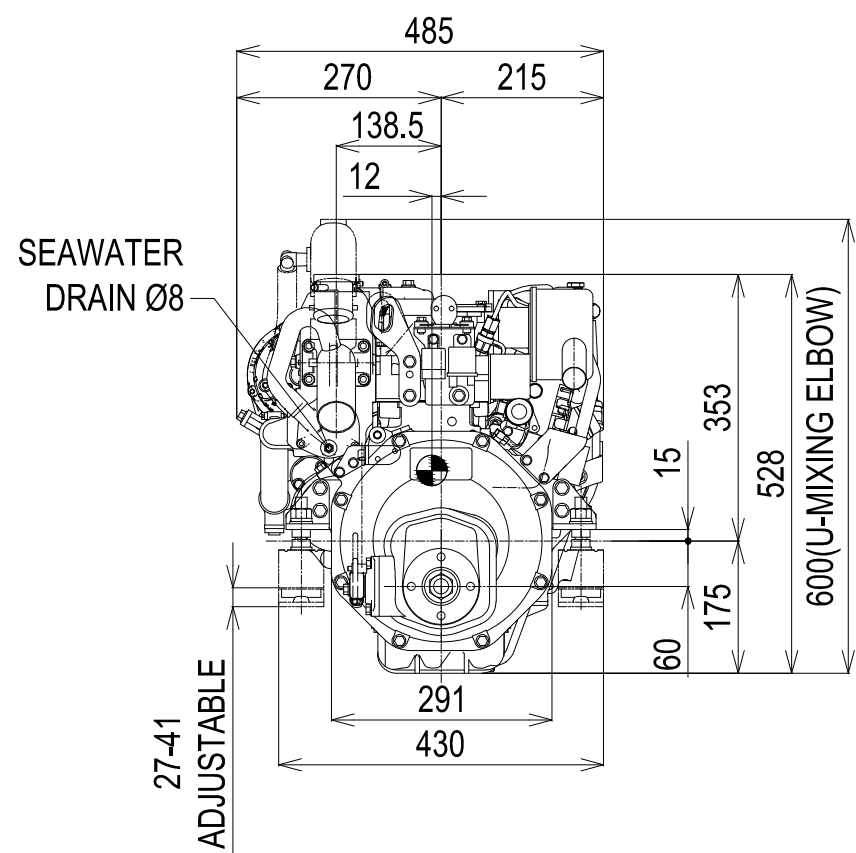
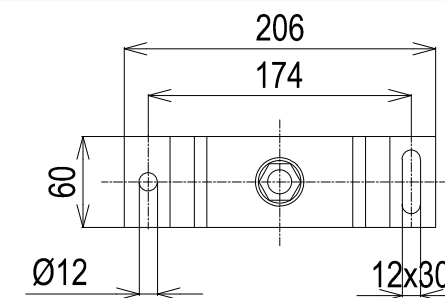
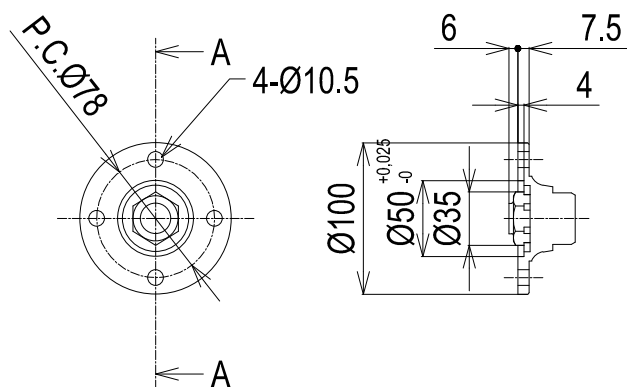

**DIRECTION OF ROTATION**

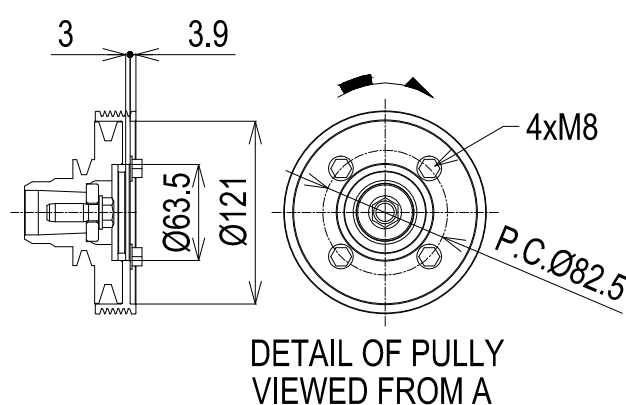

**NOTE:**

- 1.DWG.SHOWS MOUNTING BLOCKS AT ORIGINAL HEIGHT. ENGINE WEIGHT WILL COMPRESS BLOCKS BY 4.5 MM(APPROX).
- 2.MOUNTING BLOCKS ARE EQUIPPED FOR STANDARD ACCESSORY.
- 3.● SHOWS THE CENTER OF GRAVITY.
- 4.FOR ADDITIONAL INSTALLATION INFORMATION AND SPECIFICATIONS PLEASE REFER TO THE YANMAR ENGINE INSTALLATION MANUAL

Engine: 3YM20\_KM2P1

Release: 26-11-2012

Scale: 1:10

Date: 01-06-2013

Dimensions: mm